

Orbital 3400X Enhanced External Reference C-Band LNB

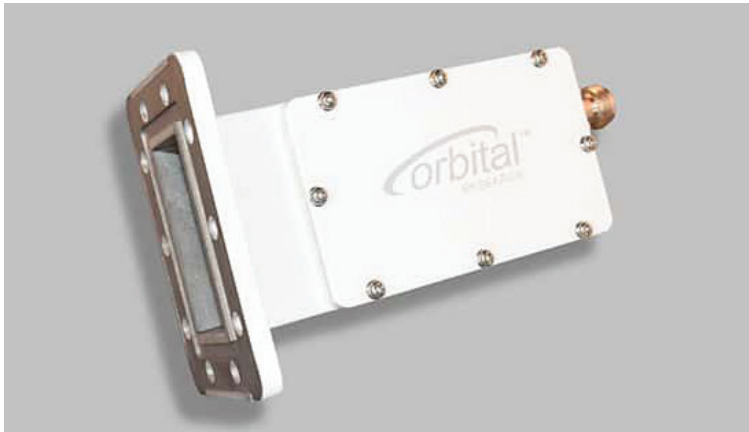

This external reference C-band LNB is enhanced to meet demanding specifications such as superior gain flatness, local oscillator (LO) stability and VSWR. The unit provides bandwidth of up to 800 MHz in the 3.40 to 4.20 GHz frequency range – and offers options like temperature-compensated gain and gain variations between 40 and 60 dB. This LNB is built for commercial and military SATCOM applications and is a great choice to help mitigate rain fade in temperate regions.

- Customizable C-band LNB
- External 10 MHz reference
- Tuned to meet demanding specs
- Ideal LNB for rainy regions

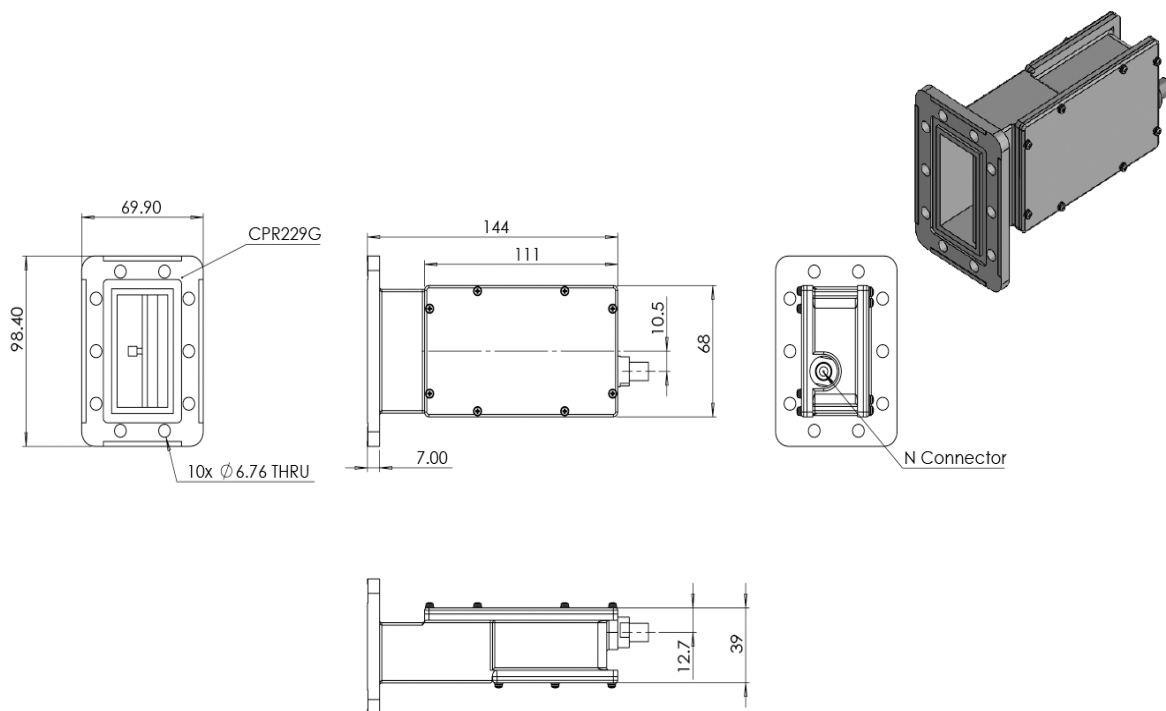

FREQUENCY RANGE

RF Frequency Band (GHz)	3.4 to 4.2
IF Frequency Band (MHz)	950 to 1750
Bandwidth (MHz)	500, 575 or 800
Local Oscillator (GHz)	515
Noise Figure (dB)	25K @ 25C
LO Stability	Locked to external reference
LO Phase Noise	Locked to external reference

10 MHz REFERENCE

Insertion	via input connector
Level	-8 to 0 dBm

VSWR

Input	2.2:1 nominal
Output	1.5:1 nominal

GAIN

Gain (dB)	60 nominal
Ripple	+/- 1 dB over any 36 MHz

OTHER SPECS

Image Rejection	> 45 dBc max
1 dB Compression (dBm)	+10 dBm min
OIP3 (dBm)	+20 dBm min

ENVIRONMENTAL

Operating Temp	-40C to +60C
Non-Operating Temp Range	-40C to +70C
Humidity	100% condensing
MTBF	> 700,000 hours
Standards	RoHS and REACH

POWER¹

Current Draw	300 mA max
Filtering	Transient, over and reverse voltage protection
Input Voltage Range	+12 to + 24 VDC

MECHANICAL

Weight (grams)	580
Length (mm)	144
Width (mm)	68
Depth (mm)	39
Input Connector	WR-229G
Output Connector	F, N, SMA, TNC

OPTIONS

Temperature compensated gain (-20C to +55C) +/- 0.75 dB
Gain options 40 or 50 dB

Please contact Orbital Research for ordering information: sales@orbitalresearch.net

¹ Power supplies must meet 100 mV maximum ripple and noise