

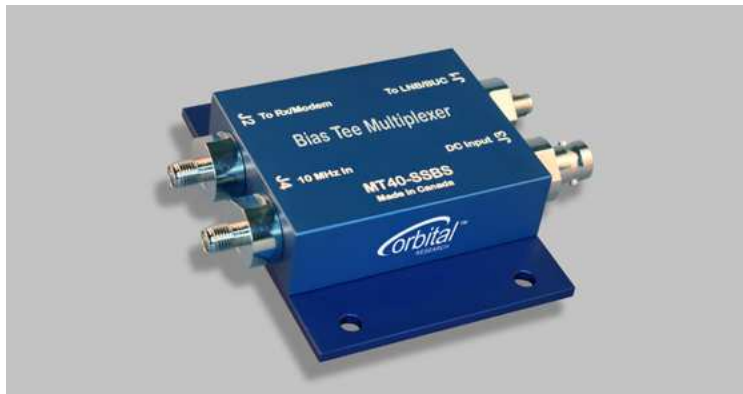

Orbital Mux-Tee (Bias Tee Multiplexer)



The Orbital Research “Mux-Tee” (MT-25/40) is a premium bias tee multiplexer that does much more than insert DC current: it multiplexes a 10 MHz reference signal onto the L-band signal. And because it is a passive device that requires no power, it can work in reverse and extract a DC signal and/or demultiplex a 10 MHz reference from your modem.

The Mux-Tee is 6 devices in 1: bias tee, 10 MHz multiplexer, both a bias tee and 10 MHz mux, DC extractor, 10 MHz demultiplexer, and both a DC extractor and 10 MHz demux.

The Mux-Tee filters the incoming IF signal and provides an effective block to any unwanted DC or 10 MHz that may be coming from the modem – delivering exceptional return loss and very low thru loss. In addition, the external DC and 10 MHz inserted signals are filtered to avoid any interference with the wanted IF signal. Other features include:

- Small and compact with customizable form factors
- Mounting plate or thru holes
- Stackable with Orbital oscillator products
- Choice of impedance and connectors: BNC (50 Ohm), F (75 Ohm), N (50 Ohm), SMA (50 Ohm), etc. at no extra charge
- Blue anodized finish, suitable for indoor/outdoor use over extreme temperatures

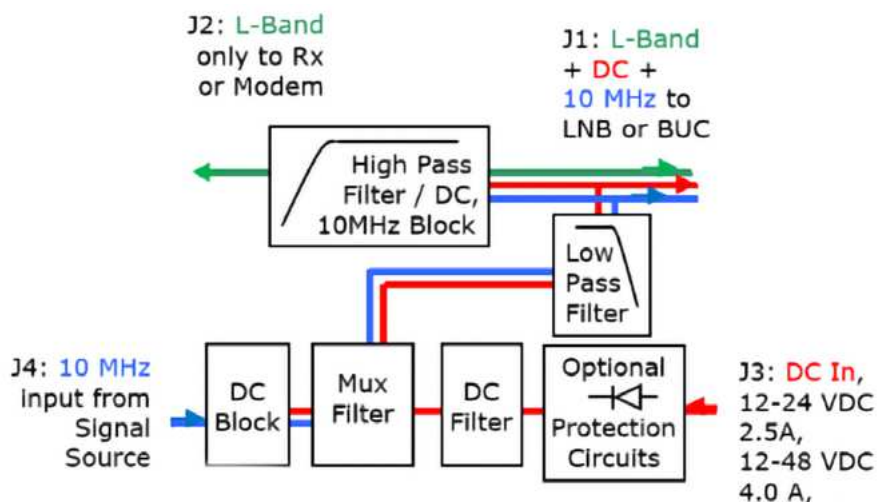

ELECTRICAL

L Band	
Bandpass	900 to 2100 MHz 900 to 3500 MHz option
Thru Loss	0.5 dB maximum
Return Loss	20 dB minimum
Ripple	±0.3 dB maximum
Input VSWR	1.3 : 1 maximum
Output VSWR	1.3 : 1 maximum
Thru Loss Above 1200 MHz	2.1 to 3.4 GHz, 0.7 dB max 3.4 to 4.2 GHz, 1.5 dB max

10 MHz	
Passband	1-100 MHz (3 dB down)
Thru Loss	0.3 dB 10 MHz to LNB port maximum
Isolation	>90 dB 10 MHz to Rx port

DC	
Filtering	Hash filter, low pass filter
Resistance	0.132 ohms (average) Power is on the center pin

MECHANICAL

Measurements	Tolerance ±.005 in.
Size (case)	3.425l x 2.55w x 0.88h in.
Size (with conn)	3.425l x 3.8w x 0.88h in.
Weight	5 oz
Paint / Colour	Blue anodized finish
Mounting Holes	3/8" (5mm) Accepts standard rackmounting screws 10/32 or 10/34

RoHS & REACH Compliant

ENVIRONMENTAL

Operating Temp	-40 to +60° Celsius
Relative Humidity	Up to 100% condensation and frost
MTBF	>125,000 hours

POWER SPECIFICATIONS

Input DC Voltage	Passive device No power required
Power Capacity	12 to 24 VDC - 2.5A, 12 to 48 VDC - 4.0A,

SWITCHING POWER SUPPLY

(not included with Mux-Tee)

See: PS1 brochure for N. America
PS2 brochure for Global

CONNECTORS AVAILABLE

J1, J2: L-Band ports	S - SMA 50Ω F - F, 75Ω N - N, 50Ω
J3: DC Supply	B - BNC (preferred) S - SMA N - N T - TNC ft - feedthru
J4: 10 MHz	S - SMA (recommended) B - BNC T - TNC N - N

HOW TO ORDER

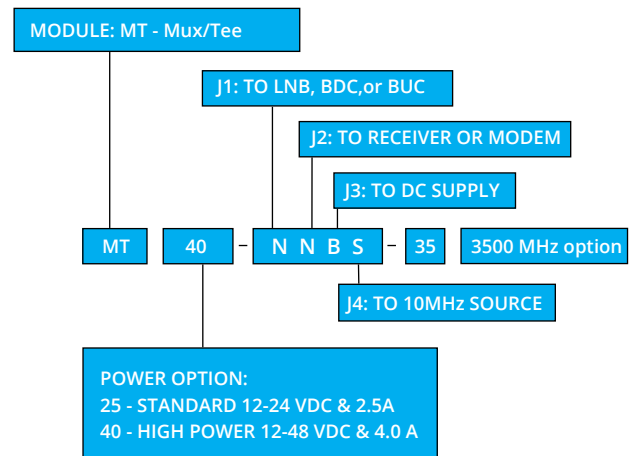

For more information to order, please contact us at sales@orbitalresearch.net